

GENERATING SET GE 4000 KDM

The images are for reference



FEATURES

- Manual recoil
- Sockets 1x 230V 16A 2P+T CEE
1x 230V 16A 2P+T Schuko
- Overload thermal shut off
- Battery charger 12 Vcc with fuse protection
- Protective frame
- Portable
- Meets EC directives of safety



Air cooling



diesel



single-phase



manual recoil

POWER RATINGS

* Stand-by single-phase power	4 kVA (3.6 kW) / 230V / 17.4 A
* PRP single-phase power	3.7 kVA (3.3 kW) / 230V / 16 A
* COP single-phase power	/
Frequency	50 Hz
Cos φ	0.9

* Output powers according to ISO 8528

DEFINITIONS

Valid declared powers up to the followings environmental conditions: temperature 25°C, altitude 100 meters above sea level)

LTP stand-by power: Maximum available power for use with variable loads for a yearly number of hours limited at 500 h. No overload is admitted.

PRP power: Continue power with variable loads. Maximum power for use with variable loads for a yearly unlimited numbers of hours.

COP power: COP Power: continuous power with constant load. Maximum power for use with constant loads for a yearly unlimited numbers of hours.

3000 RPM ENGINE

4-STROKE, DIRECT INJECTION, NATURAL ASPIRATED

Model	KOHLER - KD350
* Stand-By net power	4.6 kWm (6.3 hp)
* PRP net power	4.3 kWm (5.8 hp)
* COP net power	/
Cylinders/ Displacement	1 / 349 cm ³ (0.349 lt)
Bore / Stroke	82 / 66 (mm)
Compression ratio	20.3 : 1
BMEP (Brake Mean Effective Pressure : LTP - PRP)	/
Speed governor type	Mechanical
FUEL CONSUMPTION	
110 % (Stand-By power)	260 g/kWh - 1.4 l/h
100 % of PRP	260 g/kWh - 1.3 l/h
75 % of PRP	260 g/kWh - 1 l/h
50 % of PRP	260 g/kWh - 0.6 l/h
COOLING SYSTEM	
Total system cap. - only engine	/
Fan air flow	-5 m ³ /min
LUBRIFICATION SYSTEM	
Total oil system capacity	/
Oil capacity in sump	1.2 lt.
Oil consumption at full load	0.005 l/h

* Output powers according to ISO 3046-1

EXHAUST SYSTEM

Maximum exhaust gas flow	/
Max. exhaust gas temp.	/
Maximum back pressure	/
External diameter exhaust pipe	/
ELECTRICAL SYSTEM	
Starter motor power	/
Battery charging alternator cap.	/
Cold star	/
Cold start aids	/
AIR FILTER	
Combustion air flow	0.5 m ³ /min
HEAT REJECTED AT FULL LOAD	
To exhaust system	/
To water and oil	/
Radiated to room	/
To charge cooler	/



ALTERNATOR

SYNCHRONOUS, SINGLE-PHASE, SELF-EXCITED, SELF-REGULATED, BRUSHLESS	
Continuous power	4.2 kVA
Stand-By power	4.6 kVA
Single phase voltage	230 Vac
Frequency	50 Hz
Cos ϕ	1
Model A.V.R.	/
Voltage regulation acc	$\pm 5\%$
Sustained short circuit current	3 In
Transient dip (100% load)	< 15 %
Recovery time	/
Efficiency at 100% load	75 % (230V - Cos ϕ 1)
Insulation	Class H
Connection - Terminals	Series - n°2
Electromagnetic compatibility (R.F.I. suppr.)	EN 55011
Waveform distorsion - THD	< 6 %
Telephone interference - THF	/

REACTANCES (4.2 kVA - 230 V)	
Direct axis synchronuos - Xd	/
Direct axis transient - X'd	/
Direct axis subtransient - X''d	/
Quadrature axis synchronuos. - Xq	/
Quadr. axis subtransient - X''q	/
Negative sequence - X2	/
Zero sequence - X0	/
TIME CONSTANTS	
Transient - T'd	/
Subtransient - T''d	/
Open circuit - T'do	/
Armature - Ta	/
Short-circuit ratio Kcc	/
IP protection degree	IP 23
Cooling air flow	0.062 m ³ /sec
Coupling - Bearing	Direct J609b - N°1

GENERAL SPECIFICATION

Tank capacity	4.3 lt.
Running time (75% of PRP)	4.3 h
Start battery	/
IP protection degree	IP 23

* Acoustic power LwA (pressure LpA)	99 dB(A) (74 dB(A) @ 7m)
Performance class	G2

* Acoustic power according to European Directive 2000/14/CE

CONTROL PANEL

- Thermal circuit breaker for 230V/16A sockets
- Earth terminal (PE)
- Output terminals for 12 Vdc (battery charger)
- Fuse for 12Vdc output

COMBINATIONS AVAILABLE SOCKETS

	VERSIONS	
	STANDARD	SCHUKO
1x230V 16A 2P+T CEE	•	
1x230V 16A 2P+T Schuko	•	
2x230V 16A 2P+T Schuko		•



WEIGHT - DIMENSIONS AND ACCESSORIES

GE 4000 KDM



DRY WEIGHT OF MACHINE:

- 64 kg

Generating set pictured may include optional accessories.



DIMENSIONS PICTURE

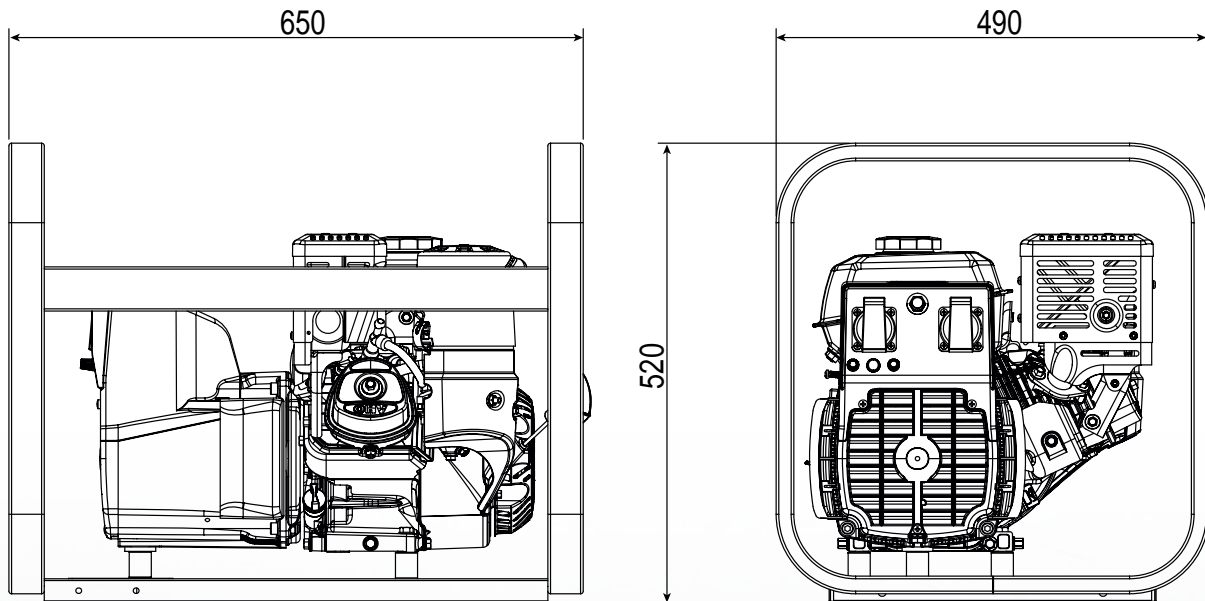

OPTIONS ON REQUEST

- Earthing kit
- Moving trolley CM8



VERSIONS ON REQUEST

- Schuko sockets version



FACTORY INSTALLATION OPTIONS

- /

GENERAL INFORMATION

COMPLIANCE GENERATING SETS WITH EC DIRECTIVES AND STANDARDS

- 2006/42 / EC (Machines Directive)
- 2014/35 / EU (Low Voltage Directive)
- 2014/30 / EU (EMC Directive)
- 2000/14 / EC (Directive Acoustic Emission for machines for use outdoors)
- ISO 8528 (Reciprocating internal combustion engine driven alternating current generating sets)



ISO 9001:2015 - Cert. 0192

WARRANTY

All devices are covered by the manufacturer's warranty.

The company reserves the right to change this specification without notice. For further information please contact the sales department.

© MOSA - Viale Europa, 59 - 20090 Cusago (Milano) - Italy - phone +39-0290352.1 - fax + 39-0290390466 E-mail: info@mosa.it Web site: www.mosa.it

